



General Features

High efficiency motors

the YDS motors are designed with new European standard for high efficiency.

MS series is designed and manufactured in according to the parameters of the new international standard 60034-30-1 for efficiency IE1, IE2.

YDSA, YDSC series are designed and manufactured in accordance with the parameters of the international standard 60034-30-1 for efficiency IE1, IE2, IE3, IE4

The motors are totally enclosed, fan cooled, with squirrel cage rotor.

MS, YDSA series, from frame 56 to frame 160 with aluminum frame.

YDSC series from frame 80 to frame 355 is with cast iron frame.

IEC60034-30-1 standard defines IE (International Efficiency) efficiency classes of single speed three phase cage induction motors; 50Hz and 60Hz; 2, 4, 6, 8 poles; rated voltage up to 1000V; S1 duty in the new standard.

IE1 standard efficiency

IE2 high efficiency from 0.12kw to 375kw

IE3 premium efficiency from 0.12kw to 375kw

IE4 super premium efficiency from 0.12kw to 375kw

Output kW	IE1 Standard efficiency				IE2 High efficiency				IE3 Premium efficiency				IE4 Super Premium efficiency			
	2 pole	4 pole	6 pole	8pole	2 pole	4 pole	6 pole	8pole	2 pole	4 pole	6 pole	8pole	2 pole	4 pole	6 pole	8pole
0.12	45.0	50.0	38.3	31.0	53.6	59.1	50.6	39.8	60.8	64.8	57.7	50.7	66.5	69.8	64.9	62.3
0.18	52.8	57.0	45.5	38.0	60.4	64.7	56.6	45.9	65.9	69.9	63.9	58.7	70.8	74.7	70.1	67.2
0.25	58.2	61.5	52.1	43.4	64.8	68.5	61.6	50.6	79.7	73.5	68.6	64.1	74.3	77.9	74.1	70.8
0.37	63.9	66.0	59.7	49.7	69.5	72.7	67.6	56.1	73.8	77.3	73.5	69.3	78.1	81.1	78.0	74.3
0.55	69.0	70.0	65.8	56.1	74.1	77.1	73.1	61.7	77.8	80.8	77.2	73.0	81.5	83.9	80.9	77.0
0.75	72.1	72.1	70.0	61.2	77.4	79.6	75.9	66.2	80.7	82.5	78.9	75.0	83.5	85.7	82.7	78.4
1.1	75.0	75.0	72.9	66.5	79.6	81.4	78.1	70.8	82.7	84.1	81.0	77.7	85.2	87.2	84.5	80.8
1.5	77.2	77.2	75.2	70.2	81.3	82.8	79.8	74.1	84.2	85.3	82.5	79.7	86.5	88.2	85.9	82.6
2.2	79.7	79.7	77.7	74.2	83.2	84.3	81.8	77.6	85.9	86.7	84.3	81.9	88.0	89.5	87.4	84.5
3	81.5	81.5	79.7	77.0	84.6	85.5	83.3	80.0	87.1	87.7	85.6	83.5	89.1	90.4	88.6	85.9
4	83.1	83.1	81.4	79.2	85.8	86.6	84.6	81.9	88.1	88.6	86.8	84.8	90.0	91.1	89.5	87.1
5.5	84.7	84.7	83.1	81.4	87.0	87.7	86.0	83.8	89.2	89.6	88.0	86.2	90.9	91.9	90.5	88.3
7.5	86.0	86.0	84.7	83.1	88.1	88.7	87.2	85.3	90.1	90.4	89.1	87.3	91.7	92.6	91.3	89.3
11	87.6	87.6	86.4	85.0	89.4	89.8	88.7	86.9	91.2	91.4	90.3	88.6	92.6	93.3	92.3	90.4
15	88.7	88.7	87.7	86.2	90.3	90.6	89.7	88.0	91.9	92.1	91.2	89.6	93.3	93.9	92.9	91.2
18.5	89.3	89.3	88.6	86.9	90.9	91.2	90.4	88.6	92.4	92.6	91.7	90.1	93.7	94.2	93.4	91.7
22	89.9	89.9	89.2	87.4	91.3	91.6	90.9	89.1	92.7	93.0	92.2	90.6	94.0	94.5	93.7	92.1
30	90.7	90.7	90.2	88.3	92.0	92.3	91.7	89.8	93.3	93.6	92.9	91.3	94.5	94.9	94.2	92.7
37	91.2	91.2	90.8	88.8	92.5	92.7	92.2	90.3	93.7	93.9	93.3	91.8	94.8	95.2	94.5	93.1
45	91.7	91.7	91.4	89.2	92.9	93.1	92.7	90.7	94.0	94.2	93.7	92.2	95.0	95.4	94.8	93.4
55	92.1	92.1	91.9	89.7	93.2	93.5	93.1	91.0	94.3	94.6	94.1	92.5	95.3	95.7	95.1	93.7
75	92.7	92.7	92.6	90.3	93.8	94.0	93.7	91.6	94.7	95.0	94.6	93.1	95.6	96.0	95.4	94.2
90	93.0	93.0	92.9	90.7	94.1	94.2	94.0	91.9	95.0	95.2	94.9	93.4	95.8	96.1	95.6	94.4
110	93.3	93.3	93.3	91.1	94.3	94.5	94.3	92.3	95.2	95.4	95.1	93.7	96.0	96.3	95.8	94.7
132	93.5	93.5	93.5	91.5	94.6	94.7	94.6	92.6	95.4	95.6	95.4	94.0	96.2	96.4	96.0	94.9
160	93.7	93.8	93.8	91.9	94.8	94.9	94.8	93.0	95.6	95.8	95.6	94.3	96.3	96.6	96.2	95.1
200	94.0	94.0	94.0	92.5	95.0	95.1	95.0	93.5	95.8	96.0	95.8	94.6	96.5	96.7	96.3	95.4
250	94.0	94.0	94.0	92.5	95.0	95.1	95.0	93.5	95.8	96.0	95.8	94.6	96.5	96.7	96.5	95.4
315	94.0	94.0	94.0	92.5	95.0	95.1	95.0	93.5	95.8	96.0	95.8	94.6	96.5	96.7	96.6	95.4
355	94.0	94.0	94.0	92.5	95.0	95.1	95.0	93.5	95.8	96.0	95.8	94.6	96.5	96.7	96.6	95.4
375	94.0	94.0	94.0	92.5	95.0	95.1	95.0	93.5	95.8	96.0	95.8	94.6	96.5	96.7	96.6	95.4

Standards

The MS, YDSA, YDSC series motors are complied with the following Standards:

Rating and performances

IEC 60034-1 CEI EN 60034-1

Methods for determining losses and efficiency

IEC 60034-2-1 CEI EN 60034-2

Rotating electrical machines, part 30, efficiency classes of single speed, three-phase inductions (IE code)

IEC 60034-30-1 EDITION 1

Classification of degree of protection (IP code)

IEC 60034-5 CEI EN 60034-5

Methods of cooling (IC code)

IEC 60034-6 CEI EN60034-6

Classification of type of construction mounting arrangements (IM code)

IEC 60034-7 CEI EN60034-7

Terminal markings and direction of rotation

IEC 60034-8 CEI 2-8

Noise limits

IEC 60034-9 CEI EN 60034-9

Built-in thermal protections

IEC 60034-11

Starting performance of rotating electrical machines

IEC 60034-12 CEI EN 60034 - 12

Mechanical vibrations

IEC 60034-14 CEI EN 60034-14

Dimensions and outputs for electrical machines

CEI EN50347 IEC60072-1 IEC60072-2



Mounting and Positions

Frame according to IEC 60034-7 , are defined in the following table:

Figure	Standards			Frame Sizes		
	CEI 2-14	Code I	Code II	56-160	180-280	315-355
	B3	IM B3	IM 1001	standard	standard	standard
	B3/B5	IM B35	IM 2001	standard	standard	standard
	B5	IM B5	IM 3001	standard	standard	upon request
	B6	IM B6	IM 1051	standard	upon request	upon request
	B7	IM B7	IM 1061	standard	upon request	upon request
	B8	IM B8	IM 1071	standard	upon request	upon request
	B14	IM B14	IM 3601	standard	/	/
	V1	IM V1	IM 3011	standard	standard	standard
	V3	IM V3	IM 3031	standard	standard	upon request
	V5	IM V5	IM 1011	upon request	upon request	upon request
	V6	IM V6	IM 1031	upon request	upon request	upon request
	V1/V5	IM V15	IM 2011	standard	standard	upon request
	V18	IM V18	IM 3611	standard	/	/
	V19	IM V19	IM 3631	standard	/	/



Protection

The motors protection degrees according to IEC 60034-5 standards, are:

IP 55 (standard)

totally enclosed motors, fan cooled, protected against penetration of dust and water splashes coming from any direction

IP 56 (upon request)

totally enclosed motors, protected against dust penetration and against sea waves, for use on deck.

Normally IP56 also IP55 motors are supplied with external fan (IC 411 - IC 416 or IC 418).

Upon request they can be supplied without fan. (IC410).

In this case the features, outputs and technical data will be supplied upon request.

The external fan is covered, in line with safety standards.

Motors for vertical mounting V1, V5, V1/V5, are supplied with rain cowl.(optional).

The terminal box, in aluminium or cast iron, has IP 55 or IP56 protection degree.

General Construction Features

The motors have been designed and manufactured in compliance with international standards.

YDSA and MS series are available from frame size 56 to frame size 160.

Frame and terminal box are in aluminum, fan cover is in sheet steel, flanges and shields are in aluminum.

YDSC series is available from frame size 80 to frame size 355.

Frame and terminal box are in cast iron, fan cover is in sheet steel, flanges and shields are in cast iron.

The terminal box, standard is on the top of the motor, which can be rotated in step of 90°, but can only rotate the position of the gland not the position of the T/BOX.

Fans are in nylon, upon request can be supplied with aluminium or steel sheet. Feet are removable, on all series, from frame size 56 to frame size 160.

Motor Spare Part List "Exploded Drawing"

This catalogue is only a reference for users. The concrete data be changed please contact with us before ordering.

1. Screw
2. Gasket
3. Oil seal
4. Front endshield
5. B14 flange
6. B5 flange
7. TB cover
8. TB fixing screws
9. TB upper gasket
10. Terminal board fixing nut
11. Terminal bridge
12. Terminal pin
13. Terminal shim
14. Terminal board
15. TB fixing screws
16. TB base
17. Cable gland
18. TB bottomgasket
19. Frame
20. Preload washer
21. Key
22. Rotor
23. Bearing
24. NDE endshield
25. Cooling fan
26. Fan circlip
27. Fan cover
28. Fan cover fixing shim
29. Fan cover fixing screws
30. Endshield fixing nut
31. Rivet
32. Nameplate
33. Foot fixing nut
34. Foot fixing screws
35. Foot

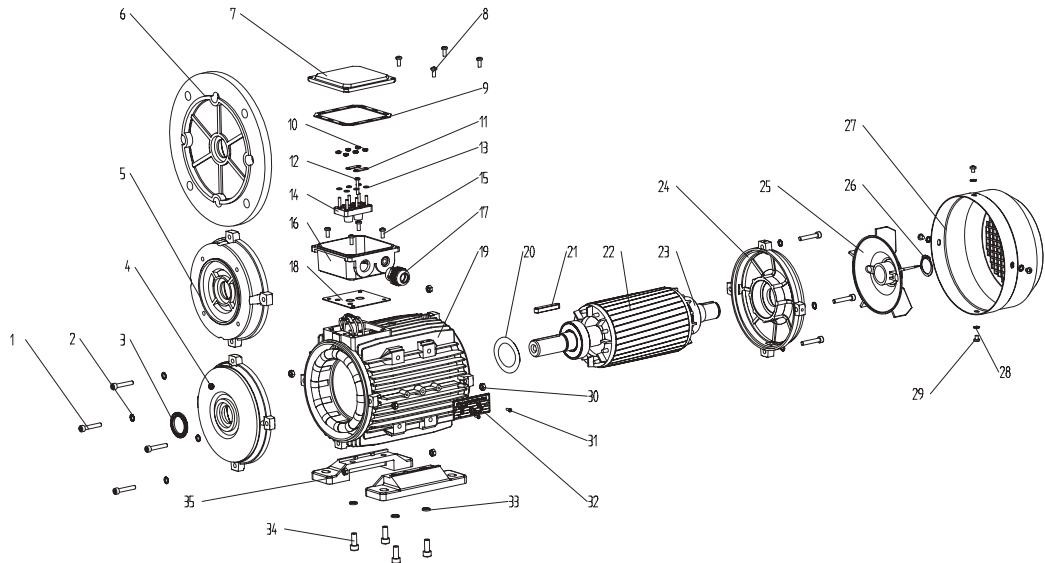

MOT.3 - 2A80B4		IM B3	SN No. 170102101		
S1-100%		Cl.F	IP56	IEC60034	
kW	V	Hz	A	COSφ	RPM
0.75	230 Δ	50	3.20	0.78	1400
0.75	400 Δ	50	1.80	0.78	1400
0.90	276 Δ	60	2.67	0.78	1640
0.90	480 Δ	60	1.53	0.78	1640

Nameplate guide:

SN NO. 170102101

1701: Production date Jan.2017

02101: Factory order No.



Cooling

The designation of cooling method is given by the IC (International Cooling) code, according to IEC 60034-6.

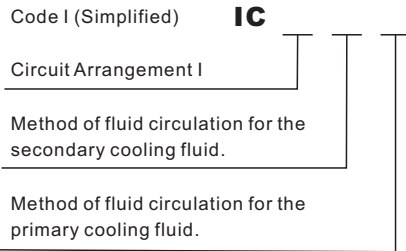

Motors in standard execution of frame sizes from 56 to 355 are supplied with IC 411 cooling systems, incorporating a bidirectional fan. All frame sizes can be supplied with cooling system IC 416 on request. In this case a proper fan is fitted inside the fan cover, suitably reinforced, in order to make the ventilation independent of the rotation speed.

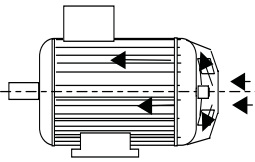
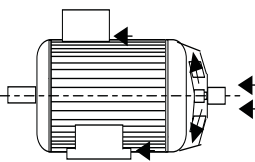
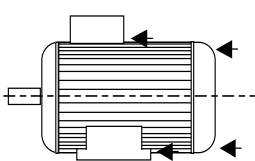
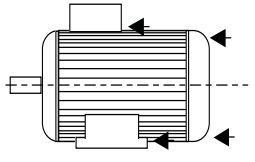
IC Code	Figure	Description	Note
IC 411		Self ventilating motor. Enclosed machine. Fan mounted on motor shaft end	Standard
IC 416		Motor with forced ventilation. Enclosed machine. Independent external fan mounted inside the fan cover.	Upon request
IC 418		Motor with external ventilation. Enclosed machine. Provided by air flowing from the driven system.	Upon request
IC 410		Non ventilated motor Enclosed machine.	Upon request



Bearings and Oil Seals

Motors YDSA series and MS series from frame size 56 to frame size 160 have sealed pre-lubricated ball bearings, DE and NDE side, C3.

Motors YDSC series frame size 132 have sealed pre-lubricated ball bearings, DE and NDE side, C3.

Motors YDSC series from frame size 160 to frame size 280 (including 315 2 pole) have ball bearings, DE and NDE, C3.

Motors YDSC series from frame size 315 (4,6,8 pole) to frame size 355, have roller bearings DE side and ball bearings NDE side.

All non pre-lubricated bearings need to periodically re-lubricated according to the data give in the motors maintenance manuals.

Motor with bearing axial constrains have an arrangement with a spring in order to absorb vibrations.

The lifetime of bearings (in accordance with supplier data) is in excess of 40.000 hours, for motors with direct coupling.

In table are mentioned all specifications concerning bearings installed on motors frame size 56-355

Motor Type	Bearing		Oil seals
	Drive end	Non-drive end	dxDxB
MS 56	6201	6201	12x22x5
MS 63	6201	6201	12x24x5
MS 71	6202	6202	15x25x7
MS 80	6204	6204	20x34x7
MS 90	6205	6205	25x37x7
MS 100	6206	6206	30x44x7
MS 112	6306	6206	30x44x7
MS 132	6308	6208	40x58x7
MS 160	6309	6309	45x65x8

Motor Type	Bearing		Oil seals
	Drive end	Non-drive end	dxDxB
YDSC 80	6204	6204	20x34x7
YDSC 90	6205	6205	25x37x7
YDSC 100	6206	6206	30x44x7
YDSC 112	6306	6306	30x44x7
YDSC 132	6308	6308	40x58x7
YDSC 160	6309	6309	45x65x8
YDSC 180	6311	6311	55x75x8
YDSC 200	6312	6312	60x80x8
YDSC 225	6313	6313	65x90x10
YDSC 250	6314	6314	70x95x10
YDSC 280	6316	6316	80x100x10
YDSC 315-2	6317	6317	85x110x12
YDSC 315-4/6/8	NU319	6319	95x120x12
YDSC 355-2	6319	6319	95x120x12
YDSC 355-4/6/8	NU322	6322	110x130x12

Motor Type	Bearing		Oil seals
	Drive end	Non-drive end	dxDxB
YDSA 56	6201	6201	12x22x5
YDSA 63	6201	6201	12x24x5
YDSA 71	6202	6202	15x25x7
YDSA 80	6204	6204	20x34x7
YDSA 90	6205	6205	25x37x7
YDSA 100	6206	6206	30x44x7
YDSA 112	6306	6206	30x44x7
YDSA 132	6308	6208	40x58x7
YDSA 160	6309	6309	45x65x8

Upon request can be mounted, roller bearings at DE side, where non-standard, insulated bearings at NDE side , and reinforced bearings at NDE side.



Terminal Box

The terminal board is normally equipped with 6 terminal and is made with non hygroscopic and middle resistance material.

Terminal box for YDSA and MS series is made in aluminum, in cast iron for YDSC series.

Terminal box has IP 55 standard protection degree or IP56.

Generally. Cable gland with the following dimensions is provided for:

Frame	Cable	Frame	Cable Gland
YDSA/MS 56	1-M16x1.5	YDSC 80	1-M20x1.5
YDSA/MS 63	1-M16x1.5	YDSC 90	1-M20x1.5
YDSA/MS 71	1-M20x1.5	YDSC 100	2-M20x1.5
YDSA/MS 80	1-M20x1.5	YDSC 112	2-M20x1.5
YDSA/MS 90	1-M20x1.5	YDSC 132	2-M25x1.5
YDSA/MS 100	2-M20x1.5	YDSC 160	2-M32x1.5
YDSA/MS 112	2-M25x1.5	YDSC 180	2-M32x1.5
YDSA/MS 132	2-M25x1.5	YDSC 200	2-M40x1.5
YDSA/MS 160	2-M32x1.5	YDSC 225	2-M50x1.5
		YDSC 250	2-M50x1.5
		YDSC 280	2-M50x1.5
		YDSC 315	2-M63x1.5
		YDSC 355	2-M63x1.5

Connection

Single speed motors

Connection star Y
high voltage on plate

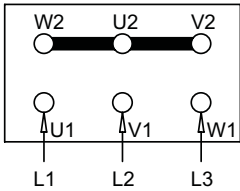

Connection Delta Δ
low voltage on plate

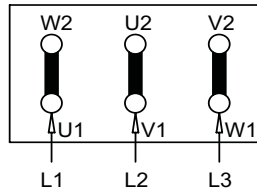

Double speed motors

Single winding
6 terminals

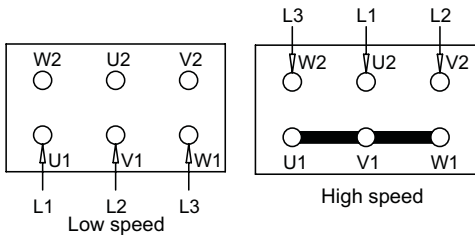

Two separate windings
6 terminals

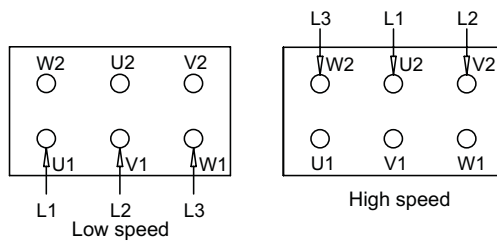



Insulation, Winding

The motors of the MS, YDSA, YDSC series are made in F insulation class. The soft copper electrolytic wire is insulated by using a special enamel (double enamel). Such enamel is classified as insulation class. All insulating materials used to produce motors are in F or H insulation class.

The winding undergoes a treatment as follows: it is impregnated by soaking it in oven-curing F class resins, it is tropicalized following a process including a spraying of anti-salty enamel and, finally, it is coated using a spray with heatproof, humidity-proof, chemical agent and sea-ambient corrosive action resistant characteristics.

The impregnation cycle is carried out under vacuum.

Ratings and Technical Data

Power and data reported in the Technical Data Tables are for continuous duty (S1) at an ambient temperature of 40 C, max. altitude 1000 a.s.l., with supply at 400 V - 50Hz.

In such conditions, the temperature rise reached by the motors lower than the one provided for by the B insulation class.

The operating characteristics are guaranteed with the tolerances defined by the CEI EN 60034-1 Standards and the IEC 60034-1 Recommendations, reported in the table

Characteristics	Tolerances
Efficiency	Motor power < 50 kW -15% of (1-η) , Motor power > 50 kW -10% of (1-η)
Power factor	+1/6 (1- cosφ) Min 0.02 Max 0.07
Locked rotor current	+20% of guaranteed value
Locked rotor torque	-15% + 25% of guaranteed value
Pull out torque	-10% of guaranteed value
Slip	± 20% of guaranteed value

Supply Voltage

The motors MS, YDSA, YDSC series from frame size 56 to frame size 250 are designed to be used for supply at rated voltages from 220V to 690V at 50Hz and at 60Hz, motors from frame size 280 to frame size 355 are designed to be used for supply at rated voltages from 400V to 690V at 50Hz and at 60 Hz.

Standard rated voltages of the motors usually in stock are:
 from frame size 56 to frame size 100, 230/400V 50Hz
 from frame size 112 to frame size 355, 400/690V 50Hz

Lower voltage is made with delta connection while the higher voltage is made with star connection. In these supply conditions efficiencies are in compliance with the IEC 60034-30-1.

Voltage and Frequency Variations

Motors can work without failures if the supply voltage variations are limited as stated in the Classification Society Standards. In particular, motors can run with voltage variations of 10% and frequency variations of 5% with a maximum combined variation of 10% with temperature rise in compliance with the provisions of the Classification Society Standards.

Operation at 60Hz Frequency

The motors can run with a frequency of 60 Hz with differences in performances and electrical ratings by applying the multiplier value as described in the table below. For motors made at 50Hz and supply at 60Hz, efficiency class of the motor at 50Hz is no longer valid

PLATE VOLTAGE 50Hz	PLATE VOLTAGE 60Hz	NOMINAL POWER	NOMINAL CURRENT	NOMINAL TORQUE	RPM	STARTING CURRENT	STARTING TORQUE	MAX TORQUE
230 +/- 10%	220 +/- 5%	1	1	0.83	1.2	0.83	0.83	0.83
230 +/- 10%	230 +/- 10%	1	0.95	0.83	1.2	0.83	0.83	0.83
230 +/- 10%	254 +/- 5%	1.15	1.02	0.96	1.2	0.93	0.93	0.93
230 +/- 10%	277 +/- 5%	1.2	1	1	1.2	1	1	1
400 +/- 10%	380 +/- 5%	1	1	0.83	1.2	0.83	0.83	0.83
400 +/- 10%	400 +/- 10%	1	0.95	0.83	1.2	0.83	0.83	0.83
400 +/- 10%	440 +/- 5%	1.15	1.02	0.96	1.2	0.93	0.93	0.93
400 +/- 10%	460 +/- 10%	1.15	1	0.96	1.2	0.96	0.96	0.96
400 +/- 10%	480 +/- 5%	1.2	1	1	1.2	1	1	1



Deratings

The tables of technical data are referred to an ambient temperature of 40°C and an altitude up to 1000 a.s.l. In different environmental conditions output ratings vary, and are obtainable by applying the factors as mentioned in the following table, maintaining the temperature rise provided for by the B insulation class.

Altitude m A.S.L	Ambient Temperature(°C)					
	30	30-40	45	50	55	60
<= 1000	1.06	1	0.97	0.94	0.9	0.87
1500	1.04	0.97	0.94	0.91	0.87	0.84
2000	1	0.95	0.92	0.88	0.84	0.81
3000	0.96	0.89	0.86	0.82	0.78	0.74
4000	0.91	0.84	0.8	0.76	0.72	0.67

In case the temperature rise permitted for the F insulation class is used, the corrective factors are the same mentioned in the following table:

Altitude m A.S.L	Ambient Temperature(°C)					
	30	30-40	45	50	55	60
<= 1000	1.17	1.12	1.09	1.06	1.03	1
1500	1.15	1.1	1.07	1.04	1.01	0.97
2000	1.13	1.07	1.04	1.01	0.98	0.95
3000	1.08	1.02	0.99	0.96	0.93	0.89
4000	1.04	0.97	0.94	0.91	0.87	0.84

All technical data reported in the tables are referred to continuous duty (S1). Upon request, motors for limited Duty S2 (30 or 60 minutes) can be supplied.

Overloads

Continuous duty motors can withstand the following overloads.

Overload %	Duration Minutes	Time Interval Minutes
10	10	15
20	6	15
30	4	15
40	3	15
50	2	15

In these operating overloads conditions, over temperature are than the limits of the insulation class F.

Starting

Motors are suitable for the following types of starting:

- Direct
- Star - delta
- By autotransformer
- Soft-start (*)
- by inverter (**)

(*)when the starting is finished soft-start should be by-passed, or precaution must be used the same when the motor powered with inverter

(**) see as recommended in the paragraph "Inverter Supply"



Noise

The technical features table contains the values of A-sound pressure level (LpA) and A sound power level (LwA), measured at a one meter distance. Sound levels are measured in no-load conditions and have tolerances of 3 dB(A).

Frame Size	A-sound pressure level (LpA) · A-sound power level (LwA) dB(A)							
	2poles		4poles		6poles		8poles	
	LpA	LwA	LpA	LwA	LpA	LwA	LpA	LwA
56	69	78	63	72	58	67	54	63
63	75	84	67	76	61	70	58	67
71	75	84	67	76	61	70	58	67
80	75	84	70	79	63	72	61	70
90	75	85	70	80	66	76	66	76
100	77	87	70	80	66	76	66	76
112	78	88	73	83	66	76	66	76
132	69	78	63	72	58	67	54	63
160	75	84	67	76	61	70	58	67
180	75	84	67	76	61	70	58	67
200	75	84	70	79	63	72	61	70
225	75	85	70	80	66	76	66	76
250	77	87	70	80	66	76	66	76
280	78	88	73	83	66	76	66	76
315	80	90	77	87	73	83	69	79
355	86	97	84	96	82	94	79	91

The values of the noise (LpA) and of the sound power (LwA) in the table are related to the operation at 50Hz, when the frequency changes these values change how indicated in the following label:

Supply Frequency Hz	Value % of the Noise level compared to the 50Hz value
10	60%
20	60%
30	70%
40	100%
50	100%
60	100%
80	120%

Vibration

Motors are dynamically balanced with a half key applied to the shaft extension in accordance with standard IEC 60034-14:2007 to vibration severity grade normal (N) in standard execution.

The following table indicates the maximum vibration grades with respect to the different shaft heights.

Vibration degree	Frame size (mm)	56≤H≤132	132<H≤280	H>280
	Mounting type	Speed/ (mm/s)	Speed/ (mm/s)	Speed/ (mm/s)
A	Suspension	1.5	2.2	2.8
	Rigid mounting	1.3	1.8	2.3



Thermal Protections

All the motors from frame size 160 to frame size 355 have installed the positive temperature coefficient thermistors PTC. These protections change its standard resistance value, Upon request, these protection, will be installed from frame size 56 to frame size 132.

Resistance of PTC, for nominal operating temperature (T), will be satisfy the following value:

- < 250 Ohm at a temperature from -20°C to TK-20°C
- < 550 Ohm at a temperature of TK-5°C
- > 1330 Ohm at a temperature of TK+5°C
- > 4000 Ohm at a temperature of TK+15°C

Values of TK related with the class of insulation are the following:

Class of Insulation	Operating Temperature limit of the Insulation °C	TK °C
A	105	95-100
E	120	110-115
B	130	120-125
F	155	145-150
H	180	170-175

The nominal operating temperature of the thermistors PTC, mounted on the YDS motors is 150' C, maximum supply voltage of the PTC theristors is 2,5V.

Below the characteristic resistance/ temperature of the PTC thermistors:

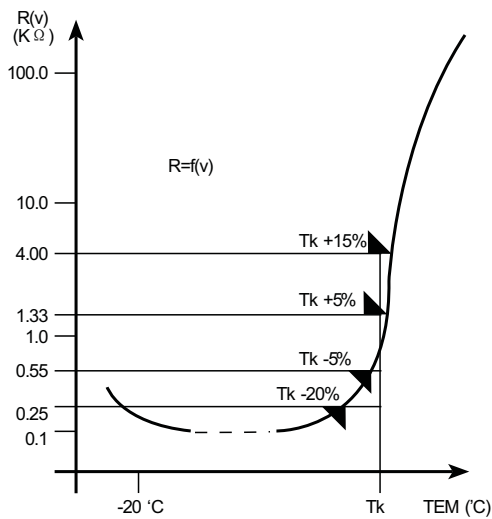

Upon request, the following thermal protections can be installed on the motors:

Bimetallic devices

Motor protectors with contact normally closed. The contact opens when the winding temperature reaches limits dangerous to the insulation system of the motor.

Platinum resistance thermometers PT100

Variable linear resistance with the winding temperature. Device particularly suitable for a continuous winding temperature monitoring.

The protection is normally made by 3 sensitive elements, one for each phase, and with two terminals in a specially provided terminal board located in the main terminal box or in a specially provided auxiliary terminal box.



Anticondensation Heaters

Motors subject to atmospheric condensation, either through standing idle in damp environments or because of wide ambient temperature variations, may be fitted with anticondensation heaters.

They are of tape form and are normally mounted on the stator winding head.

Anticondensation heaters are normally switched on automatically when the supply to the motor is interrupted, heating the motor to avoid water condensation. Normal supply voltage is 115 V or 220/240V.

Anticondensation heater terminals are led to a specially provided terminal board located in the main terminal box.

Upon request they can be led to a terminal board located in an auxiliary terminal box.

The power values normally used are shown in the table :

Frame Size	Power (W)
132-160	26
180-200	26
225-250	50
280-315	100
355	200

Drainage hole

Motors of series MS, YDSA, YDSC are provided with holes for the discharge of condensate closed with a plug to guarantee the degree of protection IP reported on plate.

As a function of the operating conditions such plugs can be removed to allow the discharge of condensate that may form inside the motor.



Inverter Supply

MS, YDSA, YDSC series are designed to be supplied by inverter. These motors can be driven up to the rated frequency (50Hz) with supply voltage proportional to the frequency. (See diagr. 1), at higher frequencies they can be supplied at constant voltage

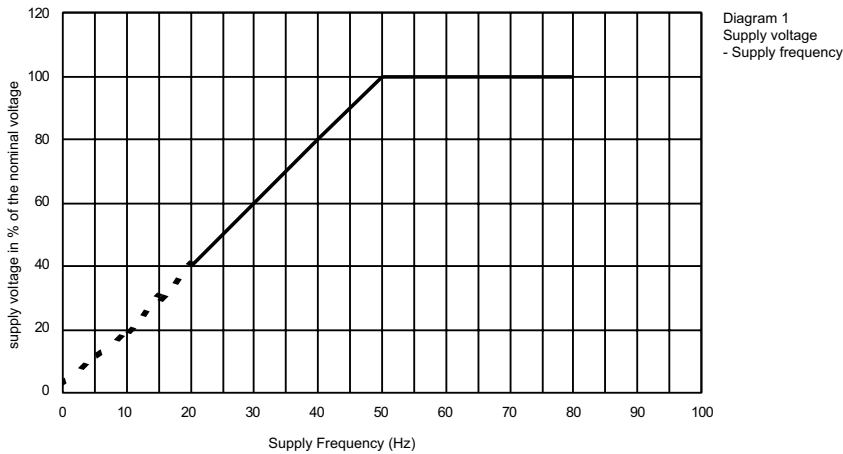

By the type of supply shown in diagr. 1, the flux created by the stator windings will be constant from 0 frequency to 50 Hz frequency, at frequencies higher than 50 Hz, the flux will be lower than the maximum nominal value.

Note: For low frequencies (0~10Hz.) due to the voltage drops, in order to keep the flux constant, the supply voltage should be slightly increased. This voltage increase depends both on the motor type and on the inverter type.

Consequently the motors in standard execution (self ventilating code IC411) are able to run at constant torque between 40 and 50 Hz and at constant power in the section included between 50 and indicated value on the refereaced.

Upon request, the MS, YDSA, YDSC series motors can be equipped with an auxiliary fan (code IC 416), in this case they can supply a constant torque between 0 and 50 Hz and a constant power in the section included between 50 and indicate dvalue on the diagram 4.

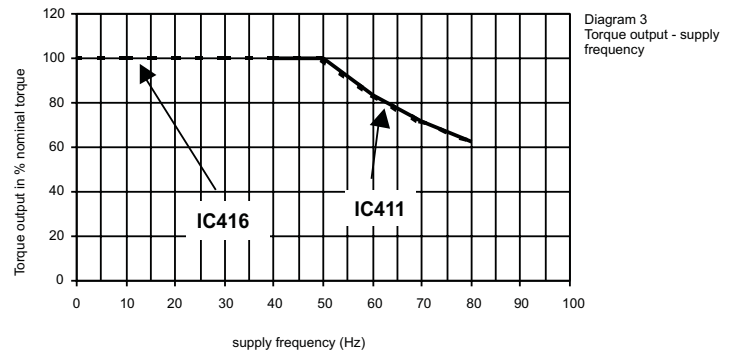
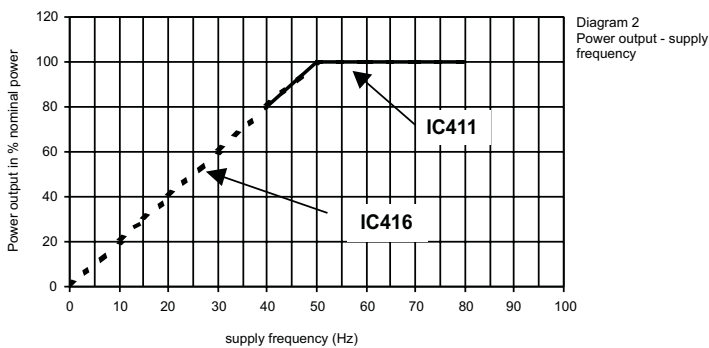

The asynchronous three-phase motors to be used for inverter supply are designed and manufactured based on design and manufacturing choices that allow an optimum and reliable operation.

It has to be considered that generally the inverter supplies the asynchronous motor with a non sinusoidal current having a certain harmonic contents. This is due in particular: to the type of inverter, to the value of the switch frequency, to the length of the supply cables.

Steep voltage fronts to the motor terminals (dv/dt) originated by the short commutation times of the IGBT, generate considerable stresses on the insulating materials.

Consequently the motor insulation must be carried out with the utmost care because it has to be able to withstand such higher stresses.



Maximum Speed

Motors supplied by inverter can run at a frequency higher than the rated one supplying the rated power up to the maximum frequency mentioned in the Diagram 4. In these conditions the motor maximum torque remains 1.6 times higher than the rated torque.

It is also possible to supply motors at an higher frequency, in this case the deliverable motor powers will be progressively reduced.

In any case the motor maximum speeds, also at no load operation or dragged by the machine, must never exceed the limit mentioned in the following table:

Frame Size	Max Permissible Speed			
	2 poles	4 poles	6 poles	8 poles
132	5000	5000	4500	4500
160	5000	5000	4500	4500
180	5000	5000	4500	4500
200	5000	5000	4500	4500
225	4500	4500	4000	4000
250	4000	4000	3800	3800
280	4000	3000	3000	3000
315	3600	2600	2600	2600
355	3600	2600	2600	2600

Maximum allowable curves, continuous duty S1, 2,4,6 poles motor with forced ventilation (IC416)

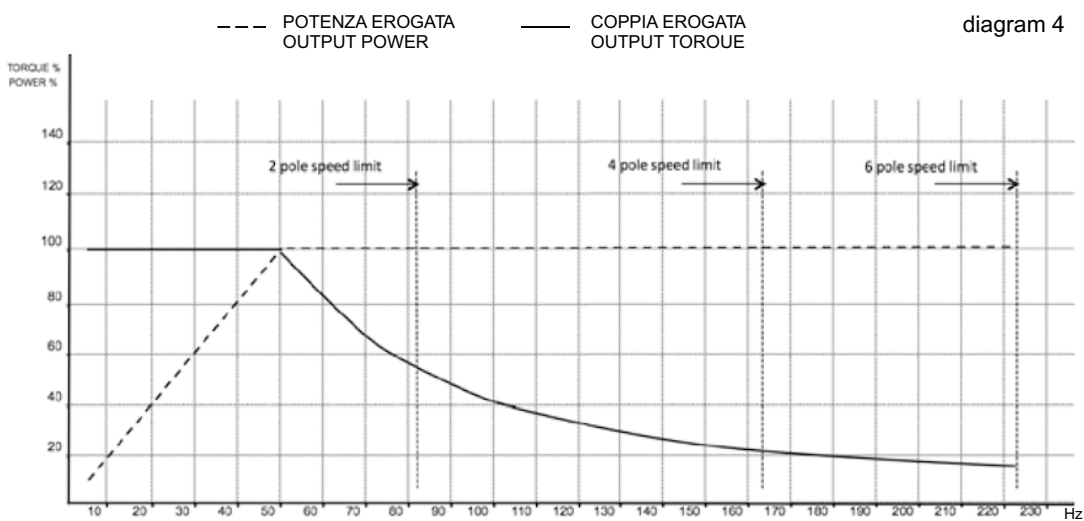



Auxiliary Fans

All frame sizes can be supplied with cooling system IC 416 (forced ventilation) on request. Consequently the ventilation is independent of the rotation speed of the motor itself.

This solution is particularly suitable for inverter supplied motors.

Auxiliary fans three phase

Type	Speed(r/min)	Maximum Air Flow (m3/h)	Maximum Pressure(Pa)	Noise dB(A)	3Phase 230V 50Hz Input Current (A)	Input Power (W)	3Phase 400V 50Hz Input Current (A)	Input Power (W)	3Phase 690V 50Hz Input Current (A)	Input Power (W)
63	2800	45	40	62	0.12	20	0.07	20	0.04	20
71	2800	52	50	62	0.14	25	0.08	25	0.05	25
80	2800	58	60	62	0.14	29	0.08	29	0.05	29
90	2800	91	80	65	0.16	32	0.09	32	0.05	32
100	2750	142	80	67	0.29	58	0.17	58	0.1	58
112	2600	229	80	67	0.31	69	0.18	69	0.1	69
132	1400	337	35	69	0.33	52	0.19	52	0.11	52
160	1390	609	40	72	0.43	70	0.25	70	0.14	70
180	1330	686	55	72	0.43	85	0.25	85	0.14	85
200	1230	1679	65	72	0.46	105	0.26	105	0.15	105
225	1430	1786	70	74	0.62	75	0.36	75	0.21	75
250	1420	1813	80	75	0.66	115	0.38	115	0.22	115
280	1360	2415	85	78	0.94	180	0.54	180	0.31	180
315	1320	2820	110	81	1.3	480	0.75	480	0.43	480
355	900	3500	800	85	1.65	400	0.95	400	0.55	400

Auxiliary fans single phase

Type	Speed(r/min)	Maximum Air Flow (m3/h)	Maximum Pressure(Pa)	Noise dB(A)	1Phase 230V 50Hz Input Current (A)	Input Power (W)	μF
63	2800	45	40	62	0.12	17	1
71	2800	52	50	62	0.17	33	2
80	2700	58	60	62	0.18	35	2
90	2300	91	80	65	0.2	45	3
100	2700	142	80	67	0.3	55	2
112	2400	229	80	67	0.37	65	2
132	1400	337	35	69	0.35	55	3
160	1400	609	40	72	0.28	55	4
180	1200	686	55	72	0.4	80	4
200	1200	1679	65	72	0.4	85	4
225	1400	1786	70	74	0.5	85	6
250	1400	1813	80	75	0.9	120	6
280	1400	2415	85	78	0.95	170	10

All frame sizes can be supplied with cooling system IC 416 (forced ventilation) on request. In the following table shown the increases of the dimension L when a forced ventilation is mounted.

Type	MS series (mm)	YDSA series (mm)	YDSC series (mm)
63	92	92	-
71	92	105	-
80	98	110	-
90	97	110	-
100	103	120	-
112	93	125	-
132	109	120	120
160	-	145	130
180	-	-	130
200	-	-	140
225	-	-	160
250	-	-	167
280	-	-	175
315	-	-	205
355	-	-	205

L standard motor + measure indicated in the table.

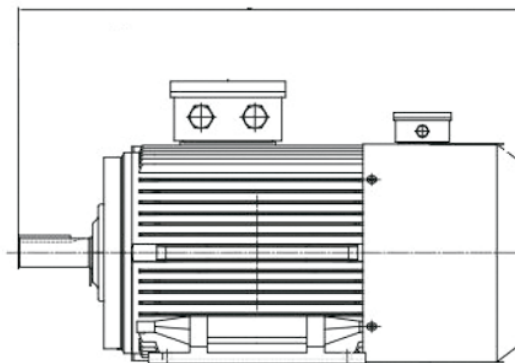



Permissible Load On The Bearings

The theoretical basic fatigue life for bearings is calculated according to the provisions of the ISO R 281-1 Standard. Life is calculated assuming that motors are running under normal ambient conditions, without abnormal vibrations, without axial or radial loads beyond the ones mentioned in the following tables and with operating temperatures of the bearings ranging between - 30 and +85 C°.

Life calculated this way is called basic life (L10h) expressed in hours of operation.

50% of bearings reaches a life equal to five times the basic life resulting from the calculation.

In table 13 are mentioned the maximum permitted axial and radial loads for a basic life (L10h) , calculated according to the provisions of the ISO Standards, equal to 20000 and 40000 hours of operation.

Values of the radial loads are given both for loads applied to the shaft extension (Xmax) and in correspondence of the face on the shaft hub (X0).

Radial loads that can be applied linearly, change with the change of the application point, therefore for loads placed at a distance X from the shaft face (X0), the maximum load that can be applied is given by the following expression:

$$F_{raX} = \frac{C_{xo} - C_{xmax}}{X_{max}} \times X + C_{xmax}$$

Where:

Fra = permitted radial load at point X

Cxo = permitted radial load at point X0

Cxmax = permitted radial load at point Xmax

Xmax = shaft extension

X = distance from the application point of the radial load to the shaft face

To verify that the belt pull does not exceed the maximum value allowed the following formula can be used:

$$F = \frac{19100 \times P \times K}{n \times D}$$

F= radial force in Nm

P= power transmitted in KW

n= numbers of revs. per minute

D= pulley diameter in meters

K= constant

Constant values K:

2	for flat pulley with tension roller
2.25	for sheaves with V belt
2.5-3	for flat belts without tension roller, or for heavy duty with any type of pulley

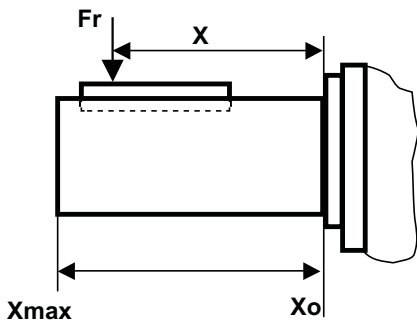

The maximum allowable radial forces, at the shaft Xmax and at the shaft collar X0, reported in the following pages are for motors having the following characteristic: standard construction, horizontal mounting IMB3 or IMB35 only, operating frequency 50Hz, bearing life of 20000 or 40000 hours according to ISO 281:1990, bearing operating temperature between -20°C to +70°C, NO external axial forces, motor installed on a rigid foundation with negligible structural vibrations.

The maximum allowable axial forces, reported in the following pages are, for motors having the following characteristic: standard construction, horizontal mounting IMB3 or IMB35 only, operating frequency 50Hz, bearing life of 20.000 or 40.000 hours according to ISO281:1990, bearing operating temperature between -20°C to +70°C, NO external radial forces, motor installed on a rigid foundation with negligible structural vibrations.